



MAHAGROUP

# MA STAR 3.5 | 5.5 | 6.5

Two Post Lifts

Extract from the Original Operating Instructions

BA364501\_101-en

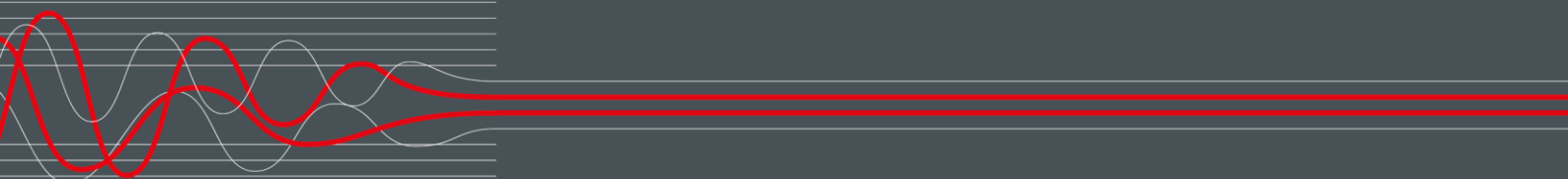

© MAHA Maschinenbau Haldenwang GmbH & Co. KG

The reproduction, distribution and utilisation of this document as well as the communication of its contents to others without explicit authorisation is prohibited. Offenders will be held liable for the payment of damages. All rights reserved in the event of the grant of a patent, utility model or design.

The contents have been checked with great care; however, errors cannot be fully excluded. Illustrations are examples and may differ from the original product. Subject to technical change without notice.

**Manufacturer**

MAHA Maschinenbau Haldenwang GmbH & Co. KG  
Hoyen 20  
87490 Haldenwang  
Germany

Phone: +49 8374 585-0  
Fax: +49 8374 585-590  
Mail: maha@maha.de  
Web: www.maha.de

**Service**

MAHA SERVICE CENTER  
Maybachstraße 8  
87437 Kempten  
Germany

Phone: +49 8374 585-100  
Fax: +49 8374 585-491  
Mail: service@maha.de  
Web: www.mahaservicecenter.de

This document is only an excerpt from the original operating instructions.  
After receipt of the delivery, the complete version of the original operating instructions must be downloaded from the MAHA website or a printout requested from MAHA.

## Contents

1	General Safety Instructions .....	4
1.1	Introduction .....	4
1.2	Symbols and Signal Words .....	4
1.2.1	Personal Injury .....	4
1.2.2	Property Damage .....	4
1.3	What to Do in the Event of Defects or Malfunctions .....	5
1.4	What to Do in the Event of an Accident .....	5
1.5	Requirements for the Operating Personnel .....	5
1.6	Requirements on Service Personnel .....	5
1.7	Intended Use .....	6
1.8	Inappropriate Use .....	6
2	Transport, Handling and Storage .....	7
2.1	Safety Instructions .....	7
2.2	Scope of Delivery .....	7
2.3	Packaging Information .....	8
2.3.1	Dimensions and Weight .....	8
2.3.2	Centre of Gravity of the Packaged Lift .....	8
2.4	Transport and Handling .....	8
2.5	Storage .....	9
3	Operation .....	9
3.1	Safety Instructions .....	9
3.2	Operation and Operating States .....	11
3.3	Preparing the Lifting Operation .....	12
3.3.1	Establishing Operational Readiness .....	12
3.3.2	Positioning the Vehicle .....	12
3.3.3	Positioning the Support Arms and Pick-up Plates .....	13
3.4	Raising and Lowering Cycles .....	14
3.4.1	Inspecting the Load Pick-up Points and Support Arm Locks .....	14
3.4.2	Lashing the Vehicle .....	14
3.4.3	Continuing the Lifting Process .....	15
3.4.4	Lowering Process .....	15
3.5	Driving the Vehicle off the Lift .....	15
4	Troubleshooting .....	16
4.1	Troubleshooting Table .....	16
4.2	Determining Defective Sensors .....	18
5	Declaration of Conformity .....	19

# 1 General Safety Instructions

## 1.1 Introduction

- These operating instructions must be read carefully and understood before work commences.
- Please observe the specific safety information provided for the respective sections of the operating instructions.
- Adhering to the procedures, sequences and corresponding safety instructions is essential.
- A printed copy of the operating instructions must always be kept by the lift.
- The relevant regulations regarding accident prevention and health and safety must be observed.

## 1.2 Symbols and Signal Words

### 1.2.1 Personal Injury



**DANGER**

indicates an immediate hazard which, if not avoided, will result in death or severe personal injury.

---



**WARNING**

indicates a potential hazard which, if not avoided, could result in death or severe personal injury.

---



**CAUTION**

indicates a potential hazard which, if not avoided, could result in moderate or minor personal injury.

---

### 1.2.2 Property Damage

**NOTICE**

indicates a potentially harmful situation which, if not avoided, could result in damage to the equipment or surrounding objects.

---

### **1.3 What to Do in the Event of Defects or Malfunctions**

- If a malfunction occurs, e.g. uncontrolled raising and lowering or in the case of load-bearing components of the structure becoming deformed, immediately lower the lift to the ground to its initial position or support the structure.
- Turn off the main switch and secure against unauthorised use.
- Contact service team.

### **1.4 What to Do in the Event of an Accident**

- Notify first aiders, the ambulance service and/or immediate care doctor:
  - Where did the accident happen (address, workshop, ...)?
  - What happened?
  - How many are injured?
  - What injuries have occurred?
  - Who is reporting the accident?
- Keep calm and answer questions.

### **1.5 Requirements for the Operating Personnel**

All persons involved in the operation of the equipment must:

- be 18 years of age or older,
- have the mental and physical capacity for their role,
- be demonstrably trained and instructed in writing in the operation of the equipment,
- have read and understood the operating instructions, and in particular the instructions on the procedure in the event of a malfunction,
- show knowledge and experience in handling the equipment and the dangers posed,
- have had certified training regarding safety regulations.

### **1.6 Requirements on Service Personnel**

Persons who are entrusted with the installation, maintenance and/or dismantling of the equipment must in addition:

- be demonstrably trained and instructed in the required work,
- can provide evidence of appropriate qualification for work on the electrical system of the equipment (e.g. as a qualified electrician),
- be able to demonstrate expertise for vehicle lifts. This includes sufficient knowledge in the field of lifts and the relevant statutory occupational health and safety regulations, accident prevention regulations and generally accepted rules of technology to be able to assess the safe working condition

of the lift to be tested.

Qualified persons shall not only consider the current condition of the lift during the inspection. They must also be able to estimate how the lift and its structural parts will behave under operational conditions in the sequence and how wear, aging and the like will affect the safety of the lift.

## **1.7 Intended Use**

- This lift is exclusively intended for the safe lifting and lowering of passenger cars and commercial vehicles within the scope of service and repair work.
- In compliance with the load distribution regulations of DIN EN 1493, the permitted load capacity on the identification plate must not be exceeded.
- Only vehicles which are suitable for the lifting equipment due to their shape and the positioning of their lifting points may be lifted.
- The lift must only be operated in the temperature range 5 to 40 °C at a maximum humidity of 50% (at 40 °C).
- The lift must be protected from direct weather conditions at all times.
- The lift must only be operated on level and sufficiently load-bearing ground (see the foundation specifications!).
- The lift must not be modified without express written permission from the manufacturer. Non-compliance invalidates the declaration of conformity.

## **1.8 Inappropriate Use**

- The lifting of other vehicles and loads is not permitted.
- Carrying of passengers is not permitted.
- Lifting the load with an additional hoist is prohibited.
- The lift must not be operated in potentially explosive and flammable operation rooms or in damp rooms (e.g. washing facilities).

## 2 Transport, Handling and Storage

### 2.1 Safety Instructions



#### WARNING

- Wear personal protective equipment.
  - Standing under a suspended load is prohibited.
  - The transport and storage of packages is only permitted using original transport racks. Observe the max. stacking height.
  - Before removing the packaging straps, secure the packages against falling and maintain a safe distance. Rebounding packaging straps can cause injuries!
  - Only lift and set up the lift columns using the marked connection points. Pay attention to the centre of gravity (marked COG).
  - Only use lifting equipment and slings that are suitable in terms of type and permitted load capacity.
  - Always ensure that the parts to be transported are suspended or loaded properly and in a fall-proof manner, taking into account their size, weight and centre of gravity. Observe transport regulations.
- 

### 2.2 Scope of Delivery

Lifts with 3.5 t load capacity are shipped ex works in one package as standard, lifts with higher load capacity in two packages. Content:

- 2 columns, screwed in racks
- 2 covers
- 1 instruction manual
- 2 sets (2 pieces each) support arms
- 4 lock elements
- 4 support discs
- 1 set impact protectors for support arms
- 1 set connector cable
- 1 cable bridge with mounting parts
- Spindle oil 500 ml
- Optional accessories

The number of delivered packages and contents must be checked for damage and completeness according to the order confirmation. Any transport damage must be documented immediately and reported to the delivery carrier.

## 2.3 Packaging Information

### 2.3.1 Dimensions and Weight

MA STAR type	3.5 A	3.5 S	5.5	6.5
Dimensions [mm]	2925 x 1100 x 710		3185 x 760 x 960	3185 x 800 x 1000
Weight approx. [kg]	2x 740	2x 720	2x 800	2x 900

### 2.3.2 Centre of Gravity of the Packaged Lift

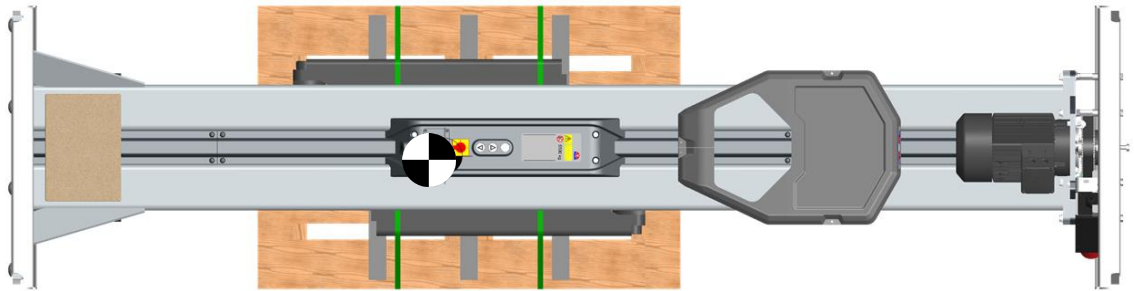

## 2.4 Transport and Handling

The transport and handling of the lift is only permitted using the original transport racks. The pick-up points shown below must be used for the loading and unloading of the packaged lift.

**IMPORTANT:** Strapping of the columns is not permitted!

The dimensions and centre of gravity of the packaged lift are shown in the section "Packaging Information".

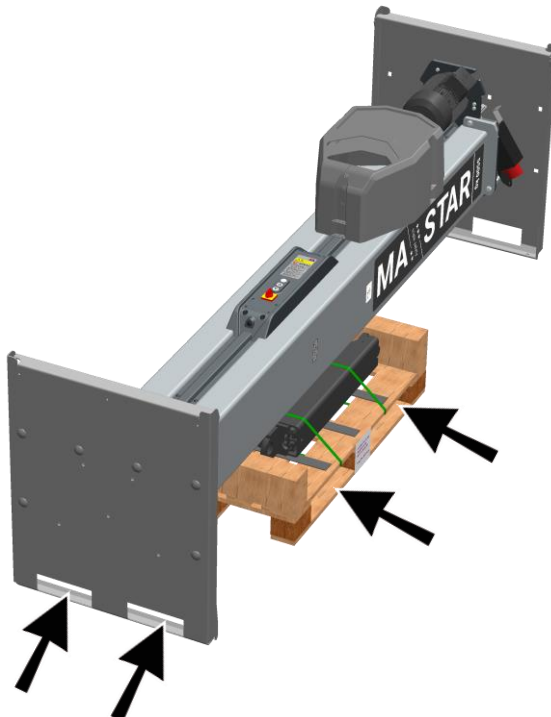



## 2.5 Storage

The packages must be stored in a covered location and protected from direct sunlight. They must be stored at low humidity and at a temperature between 0 °C and +40 °C.

The lifts may only be stacked in the original transport racks, the max. stacking height is two transport racks (see also section "Transport and handling").

Packaging waste must be disposed of in accordance with applicable environmental regulations.

## 3 Operation

### 3.1 Safety Instructions







#### WARNING

- Observe the detailed operating instructions.
- Comply with legal accident prevention regulations.
- Wear personal protective equipment.
- Perform a visual and functional check before starting work each day (see section "Semiannual exams").
- Defects must be corrected immediately in a competent manner.
- The permissible load capacity according to the type plate must not be exceeded.
- Only vehicles suitable for the lifting equipment due to their shape and the positioning of their pick-up points may be lifted.
- Operation of the lift is only permissible with mounted and intact protective covers and safety devices.
- Never touch moving parts.
- Never use additional lifting gear for an already raised load.
- Before driving a vehicle onto the lift, the support arms must be in their lowered starting position and moved backwards completely. Otherwise damage to the equipment may occur.
- Driving onto the lift should be at walking pace only and as close to the centre of the columns as possible.
- Vehicles may only be lifted with support arm locks intact and undamaged support discs. Risk of vehicle falling and causing personal injury.
- Support disc raisers may only be used in their single form. A combination of support plate elevations per support plate/arm is not permitted.
- Maintain a safe distance from the vehicle and lift in all directions.
- Keep the movement range of the load and lift free from obstacles. Use a guide if visibility is restricted.

- Vehicles doors must be closed during lifting and lowering.
  - The vehicle can be strapped to the lift if necessary. Shifts in the centre of gravity of the vehicle through installation/removal of heavy vehicle parts may otherwise lead to the vehicle sliding off.
  - After raising just off the floor, check that the vehicle has been picked up securely and that the support arms are locked correctly. If necessary, lower the vehicle and pick up again.
  - The transport of passengers is prohibited.
  - Climbing up the lifted vehicle or the lift is prohibited.
  - There should not be any people or objects within the safety zone of the lift and the load during the lifting and lowering process.
  - Monitor the load and the lift during lifting and lowering. In the event of an irregularity, the emergency stop button (main button on the main operation column or the emergency stop button on the second control unit on the opposite column), must be pressed immediately.  
**ATTENTION:** The 230V plug sockets on the operation unit(s) still carry power even after the system has been switched off!
  - There is a risk of tripping on floor-mounted lifting equipment and on the foundation anchor of the lift.
  - Parts must not be placed on the lift or the vehicle to be lifted.
  - Keep the lift and the working area clean. **ATTENTION:** Risk of slipping on oily surfaces!
  - Protect all parts of the electrical system from moisture.
  - Be careful when running vehicle engines. **ATTENTION:** Risk of poisoning!
  - Changes to or overriding of the safety features installed is prohibited!
  - Inching mode should be avoided to prevent the motor from overheating. Instead, drive briskly through.
  - During work breaks and at the end of the working day, the system must be switched off and secured against unauthorised use.
-

### 3.2 Operation and Operating States

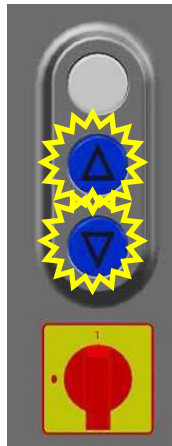
The lift has been fitted with an intuitive operating system. Depending on the operating status, illuminated buttons provide a visual indication of the lift's available options regarding direction of movement.

Status	Lift switched off	When switching on the lift	Only lifting possible	Lifting and lowering possible	Only sinking possible	Fault, lift not ready for operation
Visual indicator						
Cause		<p>3x flashing → 3.5 t 400 V 50 Hz</p> <p>4x flashing → 3.5 t 230 V 50 Hz</p> <p>or</p> <p>3.5 t 230/400 V 60 Hz</p> <p>5x flashing → 5.5 t / 6.5 t 400 V 50 Hz</p>	<ul style="list-style-type: none"> <li>- start position</li> <li>- obstacle met</li> </ul>	<ul style="list-style-type: none"> <li>- when lifting and lowering</li> </ul>	<ul style="list-style-type: none"> <li>- max. lifting height reached</li> <li>- height limit light barrier reached</li> <li>- Overload/ heavy running</li> </ul>	<ul style="list-style-type: none"> <li>- see section "Fault table"</li> </ul>

### 3.3 Preparing the Lifting Operation

#### 3.3.1 Establishing Operational Readiness



**MA STAR 3.5 A**

**MA STAR 3.5 S / 5.5 / 6.5**

- The main switch must be at position 0.
- The lift must be lowered all the way down.
- The support arms must be pivoted completely away from the working area (start position, see diagram.).

#### 3.3.2 Positioning the Vehicle

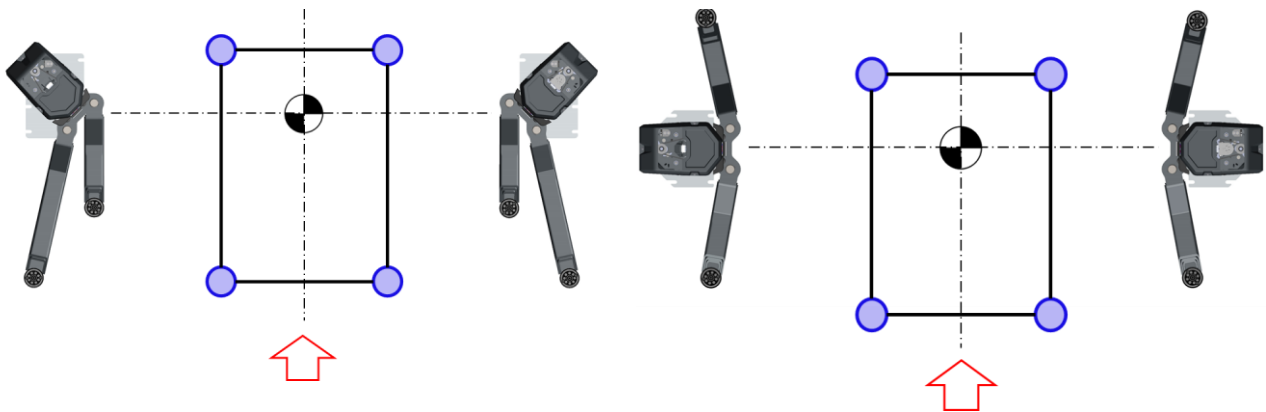

**MA STAR 3.5 A**

**MA STAR 3.5 S / 5.5 / 6.5**

- Carefully drive the vehicle forward and centrally between the lifting columns and secure it against rolling away.
- The centre of gravity of the vehicle should be as central as possible between the lift columns.
- Tip: If it is necessary to open the doors completely, the vehicle can also be positioned backwards between the lift columns.  
**IMPORTANT:** Again, ensure that the vehicle's centre of gravity is as central between the two lift columns as possible!

### 3.3.3 Positioning the Support Arms and Pick-up Plates

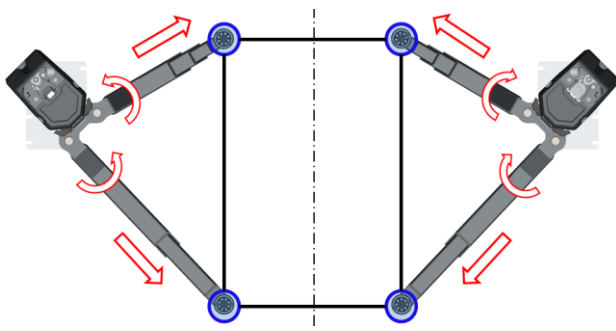

**MA STAR 3.5 A**

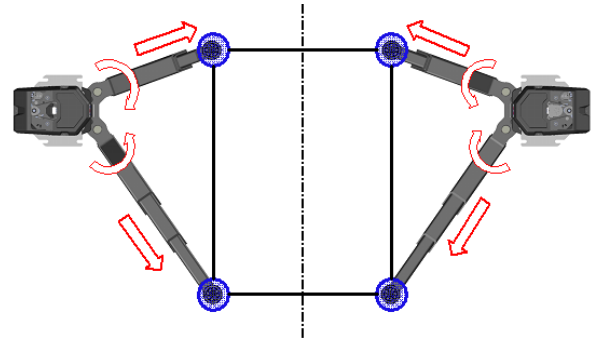

**MA STAR 3.5 S / 5.5 / 6.5**

- Swivel and extend the support arms to position the support discs under the pick-up points specified by the vehicle manufacturer. The load must rest centrally on the support plates.
- Adjust the height of the support plates so that all four support plates take the load simultaneously and evenly.

## 3.4 Raising and Lowering Cycles

### 3.4.1 Inspecting the Load Pick-up Points and Support Arm Locks



#### WARNING

Never remove lock bolts under full load!

---



- Set the main switch to position 1. After an initial flashing of all three lights, the UP button is permanently lit.
- Press the UP button until the support discs are in contact with the pick-up points of the vehicle.
- Check the position of the support discs and correct if necessary.
- Check that support arms lock securely. If necessary, move the support arms slightly until the toothed segments are engaged.

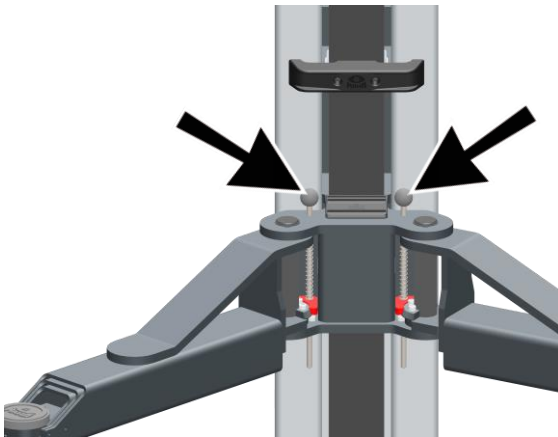

### 3.4.2 Lashing the Vehicle

The installation / removal of heavy components can lead to unintentional shifts in the vehicle's center of gravity. To prevent the vehicle from falling and causing personal injury, the vehicle must be secured to the support arms, e.g. using lashing straps.

The same applies to the lifting of partially dismantled vehicles, which are to be secured to the vehicle after start-up.

### 3.4.3 Continuing the Lifting Process



- Continue the lifting process by pressing the UP button until the desired lifting height is reached.  
UP and DOWN buttons are lit.

### 3.4.4 Lowering Process



- Before lowering the vehicle, remove tools, support blocks or similar obstacles from under the vehicle.  
The operator is responsible for ensuring that nobody is within the danger area.
- Press and hold the lit DOWN button until the desired lifting height is reached.
- The lift automatically stops when it has reached the CE-defined stop height.



- For full lowering back to the initial position, release the DOWN button after reaching the CE stop and press it again.
- UP and DOWN buttons are lit. A signal sound is activated when lowering within the CE-defined height range.

## 3.5 Driving the Vehicle off the Lift

- After the lift has been lowered completely, turn the support arms out to the side and bring them back into starting position.
- Switch off the main switch.
- Then drive the vehicle off the lift.

### **NOTICE**

There is a risk of damage to and loss of the toothed segments if the support arms come into contact with the wheels or other vehicle parts!

---

## 4 Troubleshooting

Malfunctions are interruptions in the workflow, such as may occur due to inattention or incorrect operation. Malfunctions can generally be eliminated without tools, except for the disassembly of covers.

When troubleshooting, proceed with caution. The safety instructions for operating the system apply.

### 4.1 Troubleshooting Table

Display	Diagnostics	Remedy
Signal sound immediately upon switching on.	Button pressed by mistake.	Release button.
	Control panel has short circuit.	Notify service team.
The lift stops when lowering and the blue DOWN button light goes out.	Lift has reached its end position.	Lift can only move upwards. If necessary, the lower end position can be adjusted to ground conditions by the service team.
	Signal sound when DOWN button is pressed again: Lift has met an obstacle.	Free the lift by pressing the UP button, remove the obstacle.
Support arms hit the ground during lowering.	Lower end position has not been set correctly.	Notify service team.
The lift stops when rising and the blue UP button light goes out.	Lift has reached upper end position (max. lifting height).	Lift can only be lowered.
	Signal sound when UP button is pressed again: Ceiling impact protection triggered.	Lower the lift by pressing the DOWN button. Signal tone when key is pressed again only with ceiling light barrier.
	Signal tone sounds immediately after the UP button goes out: Heavy running (max. load exceeded).	Lower the lift by pressing the DOWN button, reduce the load. Signal tone sounds immediately, without pressing the key again. (If necessary, check whether the correct stage mode is configured!)
Signal sound when lowering.	Movement within shearing zone.	No action needed.
Red fault indicator light is	Permissible tolerance	Notify service team.



<b>Display</b>	<b>Diagnostics</b>	<b>Remedy</b>
permanently on.	exceeded.	
	Signal sound when pressing the UP or DOWN button: Support nut breakage.	
Red fault indicator light flashes continuously.	Sensor malfunction.	Notify service team.
	UP and DOWN buttons flash when button is pressed: Wrong stage mode configured.	
DOWN button and UP button and red fault indicator flash more than 10 times.	Configuration mode.	Notify service team.
Red fault indicator flashes, blue DOWN button is lit.	Electrical emergency stop activated.	Lower the lift.
Red fault indicator light and blue UP/DOWN buttons are permanently lit.	Internal fault.	Turn off main switch and switch on again after approx. 5 seconds. Notify service team if the fault reoccurs.

## 4.2 Determining Defective Sensors

If the red status light on the operating unit flashes, a sensor is defective. To be able to determine the defective sensor, control lamps for each sensor are integrated on the circuit board. To do this, move the control unit to the service position (see section “The lift’s electrical connection”).

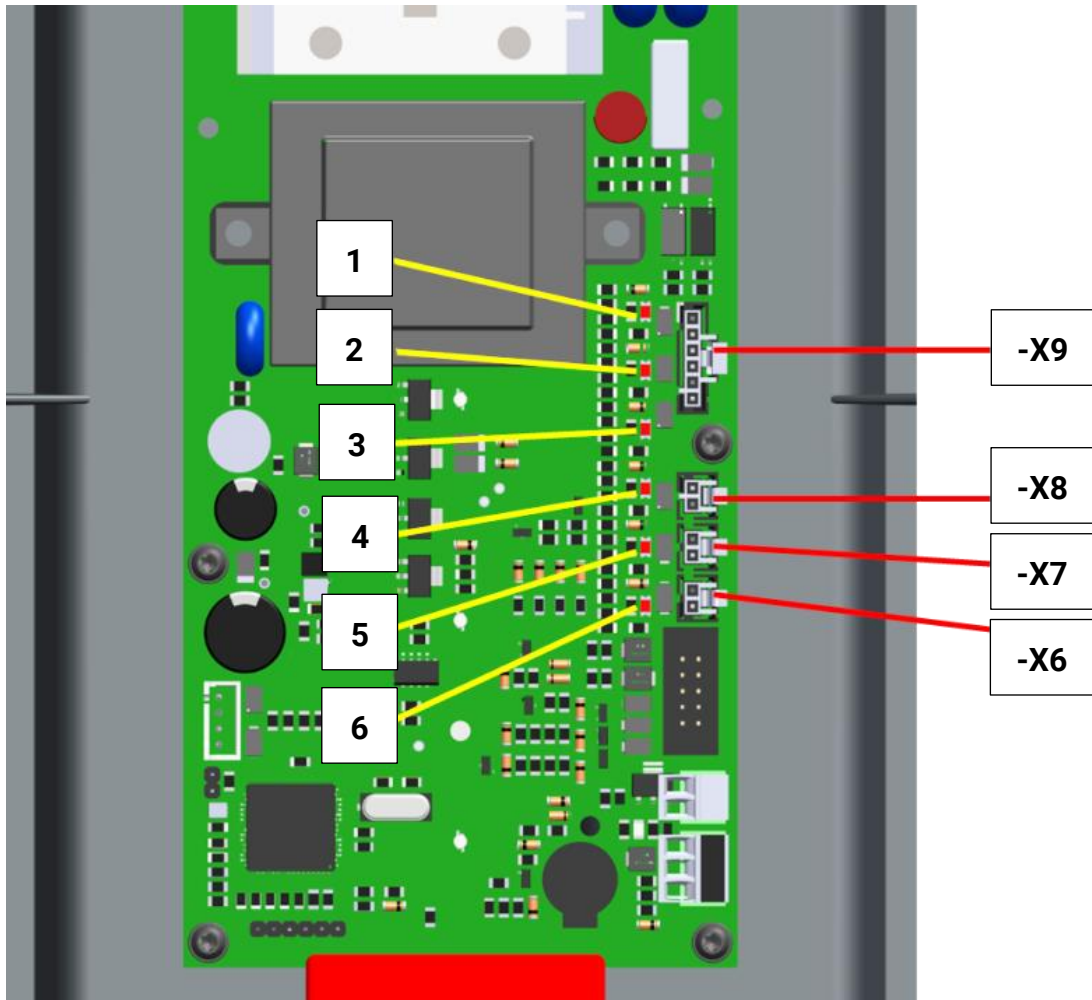

Connection	Function
-X6	Lower end position, operating column (+A)
-X7	Pulse generator, operating column (+A)
-X8	Nut fracture detection, operating column (+A)
-X9	Connecting cable, counter column (+B)

<b>Control light</b>	<b>Sensor</b>
1	Nut fracture detection, counter column (+B)
2	Pulse generator, counter column (+B)
3	Lower end position counter column (+B)
4	Nut fracture detection, operating column (+A)
5	Pulse generator, operating column (+A)
6	Lower end position operating column (+A)

The following operating states of the sensors are output via the flashing code of the control lights:

- Permanently ON Sensor covered
- Permanently OFF Sensor not covered
- 3x flashing and OFF Cable break
- 3x flashing and ON short circuit

Once the defective sensor is identified, it can be replaced. See section "Replacing and Adjusting the Sensors".

## **5 Declaration of Conformity**

See following page(s).



## Original EC Declaration of Conformity

CE364501-en



### MAHA Maschinenbau Haldenwang GmbH & Co. KG

herewith declares as a manufacturer its sole responsibility to ensure that the product named hereafter meets the safety and health regulations both in design and construction required by the directives stated below.

This declaration becomes void if any change is made to the product that was not discussed and approved by named company beforehand.

#### Model

MA STAR 3.5 A

MA STAR 3.5 A BMW

MA STAR 3.5 A MB

MA STAR 3.5 S

#### VP Number

VP 251230 | VP 251232

VP 251234

VP 251235

VP 251231 | VP 251233

#### Designation

Two Post Lift

#### Directives

2006/42/EC

2014/30/EU

#### Standards

DIN EN 1493:2010

DIN EN 60204-1

DIN EN ISO 13849-1

#### Person Authorised to Compile the Technical File

Ralf Kerkmeier

MAHA Maschinenbau Haldenwang GmbH & Co. KG, Hoyen 20, 87490 Haldenwang, Germany

Haldenwang, 2024-03-01

Dr. Peter Geigle

Managing Director



## Original EC Declaration of Conformity

CE364601-en



### MAHA Maschinenbau Haldenwang GmbH & Co. KG

herewith declares as a manufacturer its sole responsibility to ensure that the product named hereafter meets the safety and health regulations both in design and construction required by the directives stated below.

This declaration becomes void if any change is made to the product that was not discussed and approved by named company beforehand.

#### Model

MA STAR 5.5

MA STAR 5.5 MB

#### VP Number

VP 451186 | VP 451187

VP 451188

#### Designation

Two Post Lift

#### Directives

2006/42/EC

2014/30/EU

#### Standards

DIN EN 1493:2010

DIN EN 60204-1

DIN EN ISO 13849-1

#### Person Authorised to Compile the Technical File

Ralf Kerkmeier

MAHA Maschinenbau Haldenwang GmbH & Co. KG, Hoyen 20, 87490 Haldenwang, Germany

Haldenwang, 2024-03-01

Dr. Peter Geigle

Managing Director



## Original EC Declaration of Conformity

CE364701-en



### MAHA Maschinenbau Haldenwang GmbH & Co. KG

herewith declares as a manufacturer its sole responsibility to ensure that the product named hereafter meets the safety and health regulations both in design and construction required by the directives stated below.

This declaration becomes void if any change is made to the product that was not discussed and approved by named company beforehand.

#### Model

MA STAR 6.5

#### VP Number

VP 451189 | VP 451190

#### Designation

Two Post Lift

#### Directives

2006/42/EC

2014/30/EU

#### Standards

DIN EN 1493:2010

DIN EN 60204-1

DIN EN ISO 13849-1

#### Person Authorised to Compile the Technical File

Ralf Kerkmeier

MAHA Maschinenbau Haldenwang GmbH & Co. KG, Hoyen 20, 87490 Haldenwang, Germany

Haldenwang, 2024-03-01

Dr. Peter Geigle

Managing Director